

Hydrogen Bonding to the Proximal Imidazole in Heme Protein Model Compounds: Effects upon Oxygen Binding and Peroxidase Activity

Teddy G. Traylor* and Ronit Popovitz-Biro

Contribution from the Department of Chemistry, D-006, University of California, San Diego, La Jolla, California 92093. Received May 7, 1987

Abstract: The kinetics and equilibria for binding carbon monoxide or dioxygen to the previously described adamantane-heme-[6.6]cyclophane were changed very little by substituting the internally hydrogen-bonded base, 4-(2-*N*-piperidylethyl)imidazole for 1,5-dicyclohexylimidazole. By contrast, the rate of reaction of protohemin dimethyl ester chloride with *tert*-butyl hydroperoxide was accelerated by substitution of the internally hydrogen-bonded base for *N*-methylimidazole. We conclude that hydrogen bonding of the proximal imidazole increases peroxidase activity of iron(III) porphyrins but does not greatly affect oxygen affinity of iron(II) porphyrins.

The affinities of five-coordinated iron(II) porphyrins for dioxygen have been shown to depend upon steric effects operating upon either the proximal (base-binding)¹⁻³ side or distal (O₂-binding)³⁻⁶ side and to be increased by increases in electron donation to the porphyrin⁷ or to the proximal base,^{8,9} by increases in the polarity of the medium^{10,11} or local polar effects,^{10,12,13} and by hydrogen bonding to bound dioxygen.^{12b,13,14} These observations, along with heme protein crystal structures,^{15,16} suggest that hydrogen bonding to the N-H of the proximal base imidazole, by releasing electron density to the heme iron, should increase dioxygen affinity as seen in I. Similarly, it has been suggested that such hydrogen bonding in the iron(III) porphyrin complexes should increase the rate of heterolytic cleavage of the O-O bond (II) in proceeding to the high-valent iron species in peroxidases¹⁷⁻¹⁹ and in model metalloporphyrin complexes. The presence of an anionic proximal ligand in cytochrome P-450²⁰ and hydrogen-bond acceptors in peroxidases^{18b,21} has been suggested to serve this

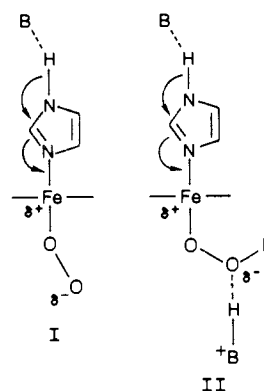

function of acceleration of production of the high-valent iron intermediate.

In an attempt to observe oxygen or carbon monoxide binding to imidazole-heme complexes, the CO affinity was found to be decreased¹⁹ but oxygen affinities have not yet been determined due to rapid oxidation of the complex.¹⁹ Similarly, attempts to use thiolate- or imidazolate-metalloporphyrin complexes as catalysts for hydroxylation reactions have been unsuccessful due to the ease of oxidation of the anionic ligands.²²

Recently, nuclear magnetic resonance^{23,24} and cyclic voltammetry measurements have indicated that iron(III) porphyrins complex with imidazole with the formation of a hydrogen-bonded form (IV),^{25,26} which results in changes in the Fe(III)/Fe(II) potential as well as ligand affinity to the Fe(III) porphyrin.²⁶

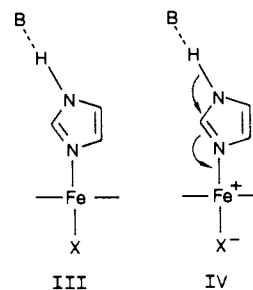

- (1) (a) Geibel, J.; Cannon, J.; Campbell, D.; Traylor, T. G. *J. Am. Chem. Soc.* **1978**, *100*, 3575. (b) White, D. K.; Cannon, J. B.; Traylor, T. G. *Ibid.* **1979**, *101*, 2443.
- (2) Linard, J. F.; Ellis, P. E., Jr.; Budge, J. R.; Jones, R. D.; Basolo, F. *J. Am. Chem. Soc.* **1980**, *102*, 1896.
- (3) Collman, J. P.; Brauman, J. I.; Doxsee, K. M.; Halbert, T. R.; Suslick, K. S. *Proc. Natl. Acad. Sci. U.S.A.* **1978**, *75*, 564.
- (4) (a) Traylor, T. G.; Campbell, D.; Tsuchiya, S. *J. Am. Chem. Soc.* **1979**, *101*, 4748. (b) Traylor, T. G.; Koga, N.; Deardurff, L. A.; Swepston, P. N. *Ibid.* **1984**, *106*, 5132. (c) Traylor, T. G.; Tsuchiya, S.; Campbell, D.; Mitchell, M.; Stynes, D.; Koga, N. *Ibid.* **1985**, *107*, 604.
- (5) Ward, B.; Wang, C.; Chang, C. K. *J. Am. Chem. Soc.* **1981**, *103*, 5236.
- (6) (a) Coliman, J. P.; Brauman, J.; Collins, T. J.; Iverson, B.; Sessler, J. L. *J. Am. Chem. Soc.* **1981**, *103*, 2450. (b) Collman, J. P. *Acc. Chem. Res.* **1977**, *10*, 265.
- (7) (a) Traylor, T. G.; White, D. K.; Campbell, D. H.; Berzini, A. P. *J. Am. Chem. Soc.* **1981**, *103*, 4932. (b) Chang, C. K.; Traylor, T. G. *Ibid.* **1973**, *95*, 8475.
- (8) Chang, C. K.; Traylor, T. G. *Proc. Natl. Acad. Sci. U.S.A.* **1975**, *72*, 1166.
- (9) Hashimoto, T.; Dyer, R. L.; Crossley, M. J.; Baldwin, J. E.; Basolo, F. *J. Am. Chem. Soc.* **1982**, *104*, 2101.
- (10) Brinigar, W. S.; Chang, C. K.; Geibel, J.; Traylor, T. G. *J. Am. Chem. Soc.* **1974**, *96*, 5597.
- (11) Suslick, K. S.; Fox, M. M.; Reinert, T. J. *J. Am. Chem. Soc.* **1984**, *106*, 4522.
- (12) (a) Momenteau, M.; Lavalette, D. *J. Chem. Soc., Chem. Commun.* **1982**, 341. (b) Mispelter, J.; Momenteau, M.; Lavalette, D.; Lhoste, J. *J. Am. Chem. Soc.* **1983**, *105*, 5165.
- (13) Chang, C. K., private communication.
- (14) Walker, F. A.; Bowen, J. *J. Am. Chem. Soc.* **1985**, *107*, 7632.
- (15) (a) Perutz, M. F. *Annu. Rev. Biochem.* **1969**, *48*, 327. (b) Perutz, M. F.; Ladner, J. E.; Simon, S. R.; Ho, C. *Biochemistry* **1974**, *13*, 2163. (c) Perutz, M. F.; Heidner, E. J.; Ladner, J. E.; Bettlestone, J. F.; Ho, C.; Slade, E. F. *Ibid.* **1974**, *13*, 2200.
- (16) Baldwin, J.; Chothia, C. *J. Mol. Biol.* **1979**, *129*, 175.
- (17) Peisach, J. *Ann. N.Y. Acad. Sci.* **1975**, *244*, 187.
- (18) (a) Poulos, T. L.; Kraut, J. *J. Biol. Chem.* **1980**, *255*, 8199. (b) Finzel, B. C.; Poulos, T. L.; Kraut, J. *Ibid.* **1984**, *259*, 13027.
- (19) Mincey, T.; Traylor, T. G. *J. Am. Chem. Soc.* **1979**, *101*, 765.
- (20) Poulos, T. L.; Finzel, B. C.; Gunzalus, I. C.; Wagner, G. C.; Kraut, J. *J. Biol. Chem.* **1985**, *260*, 16122.

- (21) de Ropp, J. S.; Thandal, V.; La Mar, G. N. *J. Am. Chem. Soc.* **1985**, *107*, 8268.
- (22) Schappacher, R. M.; Weiss, R.; Montiel-Montoya, R.; Trautwein, A. *J. Am. Chem. Soc.* **1985**, *107*, 3736.
- (23) Balch, A. L.; Watkins, J. J.; Doonan, P. J. *Inorg. Chem.* **1979**, *18*, 1228.
- (24) Walker, F. A.; Lo, M. W.; Ree, M. T. *J. Am. Chem. Soc.* **1976**, *98*, 5552.
- (25) (a) Doeff, M. M.; Sweigert, D. A. *Inorg. Chem.* **1982**, *21*, 3699. (b) Tondreau, G. A.; Sweigert, D. A. *Ibid.* **1984**, *23*, 1060.
- (26) Quinn, R.; Mercer-Smith, J.; Burstyn, J. N.; Valentine, J. A. *J. Am. Chem. Soc.* **1984**, *106*, 4136.

Table I. Spectra of Complexes of Protoheme Dimethyl Ester with Hydrogen-Bonded Imidazoles and with Anions^a

ligand	solvent	λ_{\max} , nm		
		Soret	α	β
	benzene	425	558	528
	benzene	419	566	537
	benzene	427	560	530
	benzene	421	567	537
	DMSO ^b	425	556	525
	DMSO ^b	420	569	540
	DMSO ^b	429	559	529
	DMSO ^b	430	573	542

^aSolutions were prepared and reduced as previously described.^bData are from ref 19.

Experimental Section

Instruments. The flash photolysis kinetics apparatus has been described.²⁷ Titrations and other spectrophotometric measurements were performed on a Kontron 810 spectrophotometer. NMR measurements were carried out on Varian EM390, 90-MHz CW, and 360-MHz FT spectrometers. Fourier transform IR measurements were made on a Nicolet Instruments 7199 spectrophotometer.

Materials. Toluene (Mallinckrodt) was used as received. Methylene chloride (Mallinckrodt, analytical grade) was distilled from calcium hydride. Triethylamine (Aldrich) was distilled and stored under argon. *N*-Methylimidazole (Aldrich) was distilled. 2-Methylimidazole (Aldrich) was recrystallized from benzene. Imidazole (Aldrich) was used as received. 2,4,6-Tributylphenol (Aldrich) was recrystallized from ethanol/water. *tert*-Butyl hydroperoxide (Aldrich) was distilled at 13 Torr pressure (bp 32 °C). Titration with sodium iodide revealed 98% activity.

The iron(III) porphyrins, adamantane-hemin-[6.6]cyclophane chloride (1^+Cl^-),^{4b} tetramesitylhemin chloride (2^+Cl^-),²⁸ and protohemin dimethyl ester chloride (3^+Cl^-)²⁹ were obtained from previous studies. The base 4-(2-*N*-piperidylethyl)imidazole was prepared by the method of Huebner, Turner, and Scholz.³⁰ A solution of 27 mM (2-chloroethyl)imidazole hydrochloride in 35 mL of dry 1-propanol was added to 270 mM of piperidine (Aldrich) in 25 mL of the same solvent in 1 1/2 h; the solution was refluxed 6 h and allowed to stand overnight. The white precipitate was filtered off and the mother liquor washed with 25 mL of 20% sodium carbonate, dried, and evaporated. The product was taken up in 150 mL of ethanol made acidic with 3 N HCl and crystallization induced by adding sodium acetate and cooling; yield, 64% of white crystalline product; mp after recrystallization from ethanol/2-butanol, 275–278 °C; NMR (D₂O) δ 2.1 (m, 6 H), 7.6 (s, 1 H), 8.9 (s, 1 H).

The free amine was generated by dissolving the hydrochloride in methanol, treating with excess Na₂CO₃, evaporating, and triturating with

absolute ethanol. Recrystallization from ethanol/hexanes afforded the amine: NMR δ 1.5 (m, 6 H), 2.4 (m, 4 H), 2.75 (m, 4 H), 6.68 (s, 1 H), 7.45 (s, 1 H).

Titrations. Solutions of 5×10^{-6} M adamantane-cyclophane-hemin (1^+Cl^-) were prepared and reduced in the presence of the amine and titrated with carbon monoxide as previously described.²⁷ Oxygen affinities were determined by kinetic methods as previously described.²⁷

Kinetics. Rate determinations of hemin-catalyzed oxidation of 2,4,6-tri-*tert*-butylphenol were carried out as previously described, using the indicated hemin and base concentrations.²⁹ Flash photolysis kinetic methods for determining rate association of CO or O₂ to iron(II) porphyrins have been described elsewhere.²⁷

Results

The adamantane-heme-[6.6]cyclophane (**1**) and other heme structures and the internally hydrogen-bonded imidazole (PEI) used in this study are shown.

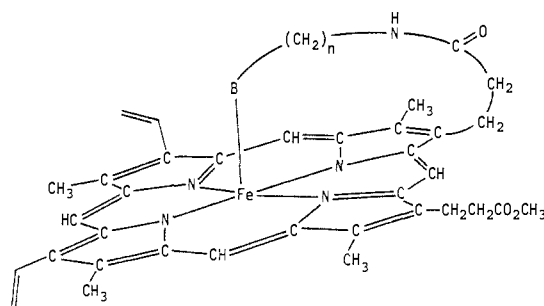
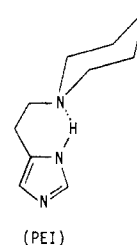
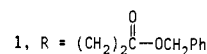
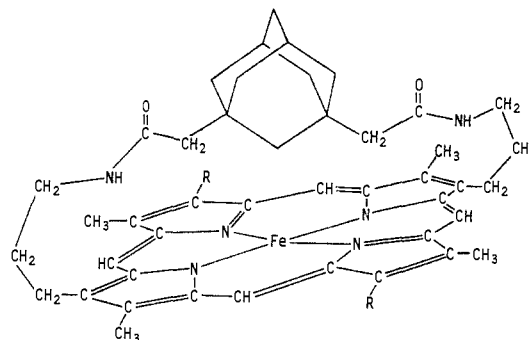

Chelated Hemin Chlorides

	n	B
4^+Cl^-	3	
5^+Cl^-	2	
3^+Cl^-	-	(protohemin dimethyl ester)

(27) Traylor, T. G.; Chang, C. K.; Geibel, J.; Berzini, A.; Mincey, T.; Cannon, J. *J. Am. Chem. Soc.* **1979**, *101*, 6716.



(28) Traylor, T. G.; Marsters, J. C., Jr.; Nakano, T.; Dunlap, B. E. *J. Am. Chem. Soc.* **1985**, *107*, 5537.

(29) (a) Traylor, T. G.; Lee, W. A.; Stynes, D. V. *J. Am. Chem. Soc.* **1984**, *106*, 755. (b) Traylor, T. G.; Lee, W. A.; Stynes, D. V. *Tetrahedron* **1984**, *40*, 553.

(30) Huebner, C. F.; Turner, R. A.; Scholz, C. R. *J. Am. Chem. Soc.* **1949**, *71*, 3942.

Internal Hydrogen Bonding. To establish that PEI is hydrogen bonded as shown, the FTIR spectrum of this compound and those of mixtures of imidazole and triethylamine in methylene chloride were compared. A solution containing 0.03 M imidazole showed a sharp single N–H stretching frequency at 3459 cm⁻¹ with or without added 0.03 M triethylamine. A 0.01 M solution of PEI

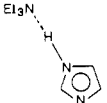
Table II. Spectra of Protohemin Dimethyl Ester with Hydrogen-Bonded Imidazoles^a in Methylene Chloride

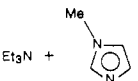
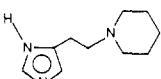
ligand	ligand concn, M	λ_{\max} , nm		
		Soret	α	β
	0.03	408	562	538
	0.03 Im/0.01 Et ₃ N	412	562	538
	0.03	410	560	530
	0.03 NMeIm/0.01 Et ₃ N	410	557	530
	0.001	412	562	535

^a See ref 19 for preparations of the solutions.

displayed a very small peak at 3459 cm⁻¹ and a large broad peak at about 3280 cm⁻¹. This spectrum is typical of an internally hydrogen-bonded N-H or OH bond.

Spectroscopic Effects of Proximal Hydrogen Bonding. Spectra of protoheme dimethyl ester complexes with various imidazoles and imidazolate ions are listed in Table I. The change in the Soret absorption of the base-CO complex upon deprotonation of the proximal imidazole is about 10 nm to longer wavelengths,¹⁹ whereas the corresponding change upon substitution of PEI for 1-methylimidazole is 2 nm to longer wavelengths, possibly indicating some increase in electron density resulting from the hydrogen bonding.

Similar behavior is seen in the iron(III) porphyrins (Table II). The bis(base) species shifts by about 2 nm upon substitution of PEI for 1-methylimidazole or upon addition of triethylamine to an imidazole-hemin complex. Both of these effects are rather small, but they are real.

It was previously shown that deprotonation of RSH-Hm-CO or imidazole-Hm-CO complexes decreases the C=O stretching frequencies by 16–20 cm⁻¹.^{19,30,31} The FTIR spectrum of the protoheme dimethyl ester complex with PEI and CO in methylene chloride reveals a CO stretching frequency of 1959.8 cm⁻¹ and a half-width of 21 cm⁻¹ compared with 1961.0 cm⁻¹ and 22 cm⁻¹ half-width for the 1-methylimidazole-CO complex under the same conditions. This is a negligibly small shift compared with that for full deprotonation of imidazole (16 cm⁻¹).

Effects of Hydrogen Bonding on Carbon Monoxide and Dioxygen Affinities and Kinetics. In order to maintain five-coordination in the "deoxy" heme and thus observe simple kinetic behavior, we have made the comparisons of PEI and 1,5-dicyclohexylimidazole (DCI)²⁷ as proximal bases using the cyclophane-heme (1). Titrations of the 1-base complexes with CO were carried out in tonometers as previously described.²⁷ The spectrum of 1-PEI complex differed from that with DCI, although the base-1-CO complexes are almost identical. Titrations with clean isosbestic points afforded K_B^{CO} values shown in Table III.

This table also lists rates of CO and O₂ reactions with the five-coordinated 1-base species as well as $K_B^{\text{O}_2}$ obtained by the kinetic method described previously.²⁷ Although there appears to be a small solvent effect on $K_B^{\text{CO}}/K_B^{\text{O}_2}$ similar to that described by Suslick,¹¹ there is no measurable effect on kinetics or equilibria upon substituting PEI for DCI.

Peroxidase Activity. The catalysis of 2,4,6-tri-*tert*-butylphenol oxidation by *tert*-butyl hydroperoxide has been studied in detail, as has the catalysis of epoxidation of iodosylbenzenes.^{28,29} Both rates are first order in oxidant and in catalyst and are independent

Table III. Kinetics and Equilibria for Reactions of Adamantane-Cyclophane-Heme (1) with CO and O₂ at 25 °C^a

	DCI		PEI	
	benzene	CH ₂ Cl ₂	benzene	CH ₂ Cl ₂
k_B^{CO} , s ⁻¹	9.2×10^3			7.0×10^3
K_B^{CO} , M ⁻¹	1.4×10^5	3.2×10^4	7.4×10^4	3.3×10^4
$K_B^{\text{O}_2}$, M ⁻¹	270			334
$K_B^{\text{CO}}/K_B^{\text{O}_2}$	518			96

^a All data using DCI as base in benzene solvent are from ref 4b. The other data were obtained in this work.

of substrate (alkene or phenol) concentration or structure. We can therefore use eq 1 to probe for the effect of proximal hydrogen bonding in the rate of formation of the high-valent iron complex (eq 3).

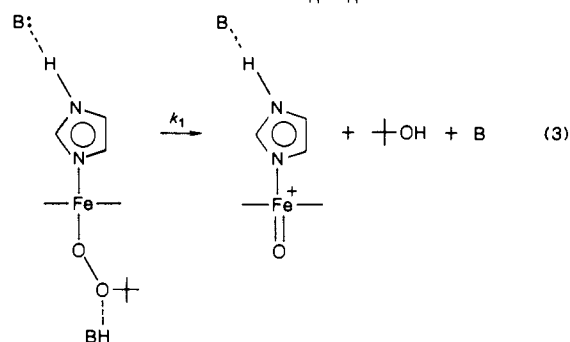
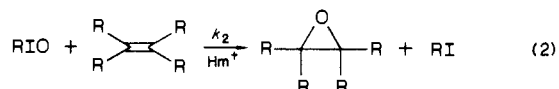
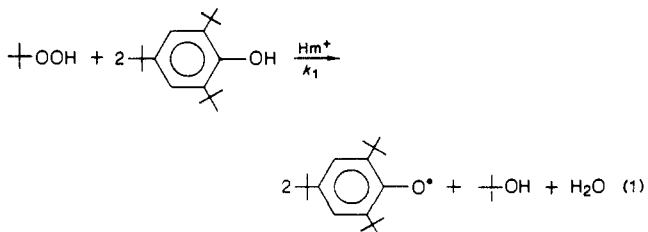

However, the addition of imidazole has the complication that six-coordination can occur and interfere with the interaction of *tert*-butyl hydroperoxide with the iron. This apparently does not result in retarding the rate of reaction, presumably due to a cancellation of the effect by an acid-base preequilibrium or general-base catalysis as shown in eq 4–8.

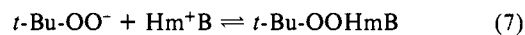
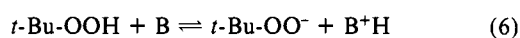
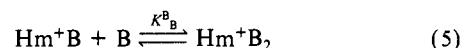
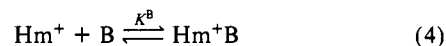

As a control with which to compare the effect of hydrogen-bonded bases such as PEI or mixtures of imidazole and triethylamine, we have used mixtures in a 1:1 ratio of 1-methylimidazole and triethylamine. Zero-order rates for the phenoxyl radical production were determined as previously described and were converted to second-order rate constants by dividing the rates by hemin and *tert*-butyl hydroperoxide concentrations. A plot of such rate constants as a function of the molarity of 1-methylimidazole (and of triethylamine as well) is shown in Figure 1. On the same figure are plotted the rate constants for similar variations in the concentration of imidazole (and triethylamine) and rate constants versus concentrations of PEI. Both of the imidazoles that are capable of hydrogen bonding show large accelerations compared with the 1-methylimidazole system. In

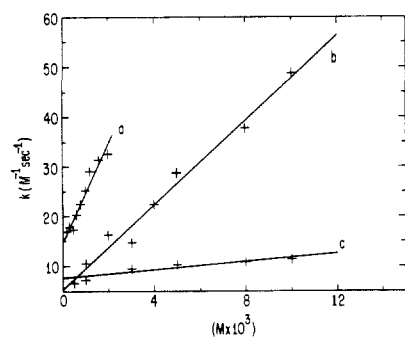

Figure 1. Plots of second-order rate constants for reaction of *tert*-butyl hydroperoxide (0.018 M) with tri-*tert*-butylphenol (0.1 M) catalyzed by protohemin chloride dimethyl ester (5×10^{-6} M) against concentration of base. Reactions were in methylene chloride at 25 °C. Base: (a) PEI; (b) imidazole plus an equal concentration of triethylamine, concentration refers to imidazole; (c) 1-methylimidazole plus an equal concentration of triethylamine, concentration refers to 1-methylimidazole.

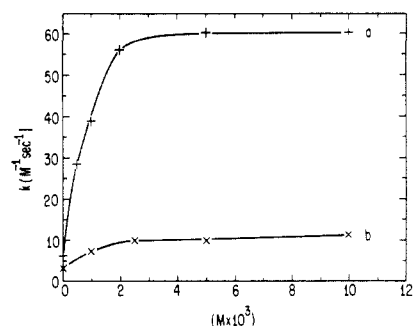

Figure 2. Rate constants for the same conditions as those in Figure 1 except that triethylamine concentration was varied and the base concentration held constant at 0.03 M. Key: (a) imidazole; (b) 1-methylimidazole.

the comparisons on this figure it is assumed that the behavior of the different imidazole is similar with respect to binding to iron (eq 4 and 5) and basicity (eq 6).

This effect is also observed upon changing the concentration of triethylamine while keeping the concentration of 1-methylimidazole or imidazole constant at 0.03 M, plotted in Figure 2. Only in the case of imidazole itself is the rate accelerated, leveling off at about 0.004 M triethylamine.

A similar plot of rate constant versus triethylamine concentration at constant concentration of 2-methylimidazole or 1,2-dimethylimidazole with the tetramesitylhemin chloride as catalyst is shown in Figure 3. Again, acceleration of the hydrogen-bonding imidazole is seen.

Discussion

The infrared spectrum of PEI provides strong evidence that it exists in solution almost entirely in the hydrogen-bonded form discussed earlier. The UV-visible spectra of the various complexes of protoheme or protohemin dimethyl esters with PEI also indicate that hydrogen bonding is present in the complexed forms. A similar internally hydrogen-bonded 3-imidazolepropionic acid ethyl ester has been studied by Valentine et al.²⁶

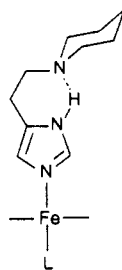

Theoretical considerations²⁴ and oxidation potentials determined by Sweigert et al.²⁵ suggest that such hydrogen bonding, having

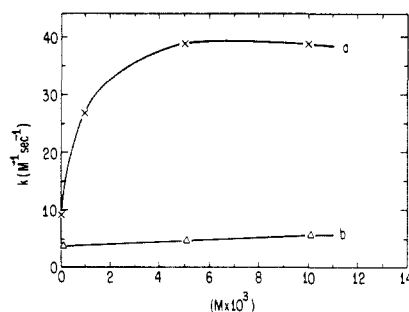
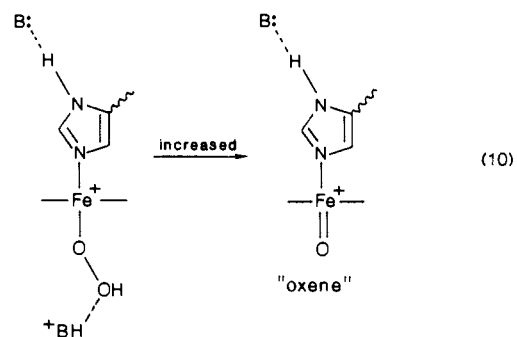
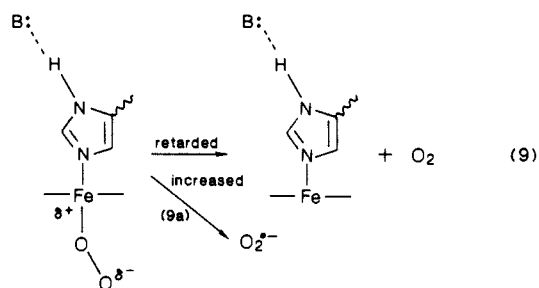

Figure 3. Plots of rate constants versus triethylamine concentrations with 5×10^{-6} M tetramesitylhemin chloride and 0.03 M base as in Figure 2. Key: (a) 2-methylimidazole; (b) 1,2-dimethylimidazole.

the effect of increasing electron density at the iron atom, should provide increasing stabilization as the oxidation state (or electron density) of the iron increases. Thus, any process that removes electron density from iron should be facilitated by such hydrogen bonding.

Application of these ideas to peroxidases as compared with myoglobin has provided a rationale for the decreased dioxygen dissociation rate as well as the increased rate of hydroperoxide cleavage in peroxidases.¹⁸

In reaction 9 the dioxygen complex, although not actually an iron(III) complex, has less electron density than does the deoxy form. Therefore hydrogen bonding should stabilize the complex while at the same time accelerating formation of the iron(III) species (eq 9a). Both are observed in peroxidases as compared



with myoglobin. Further evidence was provided by Kraut and Poulos in the crystal structure of cytochrome *c* peroxidase.¹⁸ The proximal hydrogen-bonding group (B) was found to be glutamate.

In both reactions 9 and 10 electron donation by the proximal base has been shown to be important. However, as we see in Table III, the hydrogen-bonding base PEI does not cause significant retardation of the dioxygen dissociation rate and does not increase dioxygen affinity. Either the hydrogen bonding is too weak to strongly polarize the N-H bond or else the dioxygen affinity is not very sensitive to small changes in electron density. We conclude that hydrogen bonding to the proximal imidazole is not an important factor in determining oxygen affinities or carbon monoxide versus dioxygen bonding in heme proteins. It is likely that steric and polar environment effects along with hydrogen bonding to bound dioxygen are responsible for these variations in dioxygen affinities.

The CO and O₂ dissociation rates are 100 and about 1000 times slower in peroxidases than in myoglobin or in model compounds.

Thus far no model system has displayed these extremely slow dissociation rates. Hydrogen bonding to proximal imidazole does not provide a means of reducing dissociation rates. Therefore the reason for these extraordinarily slow rates remains unknown.

Peroxidase Activity. The kinetics of reaction of iron(III) porphyrins have been widely studied in an effort to understand reactions of hydroperoxides and peracids with peroxidases and with cytochrome P-450. We recently reported an extensive study of the kinetics of reaction of chelated heme compounds and related simple hemins with peracids, hydroperoxides, and hydrogen peroxide, confirming and extending some of the previous conclusions. In particular we demonstrated that the reaction with all three classes of oxidants is first order in hemein, is first order in oxidant (peracid, hydroperoxide, or iodosylbenzene), and is general-base catalyzed. In addition, the rate correlates well with the leaving-group ability. These data were interpreted in terms of heterolytic cleavage with general-base catalysis in a process like that recently described by Groves et al.³² The initial product is the iron(IV) radical cation (see eq 12). Bruice et al.³³ confirmed

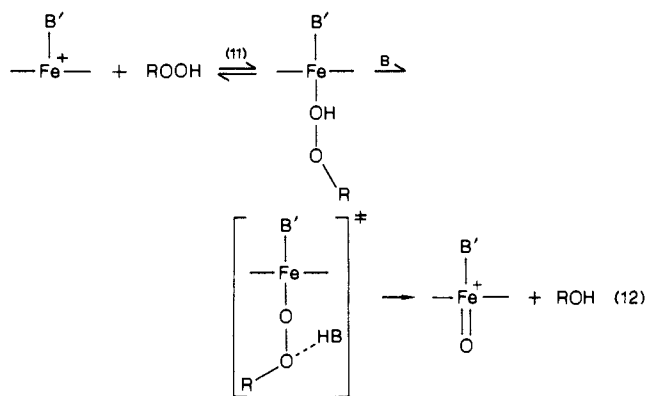

these observations, extended the studies to other metalloporphyrins, and concluded that the general-base-catalyzed reaction of peracids, hydroperoxides, and hydrogen peroxide all proceed by heterolytic cleavage. They have questioned our conclusion that the uncatalyzed ($\text{B}' = \text{H}_2\text{O}$ or Cl^-) reaction of hydroperoxides takes this pathway and have suggested that the uncatalyzed process takes a homolytic pathway on the basis of a break in his plot of log rate versus $\text{p}K_{\text{ROH}}$, the $\text{p}K_{\text{a}}$ of the leaving group conjugate acid. This difference in conclusion, which does not affect the present study where general bases are present, will be discussed elsewhere.

In our study we also noted an increased rate for chelated heme 4^+Cl^- compared with the simple heme 3^+Cl^- , which indicates the importance of proximal base upon cleavage of the O—O bond. Similar effects have been noted by Muenier³⁴ and others in the reaction of hypochlorite with Mn(III) porphyrins. In addition, the chelated heme 5^+Cl^- , bearing an N—H bond on the proximal imidazole, reacts faster than does 1^+Cl^- , which does not have the proximal hydrogen.²⁹ This was interpreted as evidence for hydrogen bonding to the proximal base in the transition state for heterolytic breaking of the O—O bond. Similar observations have more recently been described by Bruice et al.^{33a} for Mn(III) porphyrin reactions. However, our previous observations did not provide conclusive evidence for hydrogen bonding to the proximal imidazole.

We provide this evidence by keeping the proximal base constant and varying the concentration of triethylamine or by using the

preformed hydrogen-bonded base (PEI). These and our previous data,²⁹ along with recent studies of Groves et al.³² and Bruice et al.,³³ are consistent with the mechanism that Kraut and Poulos postulated for cytochrome *c* peroxidase reaction¹⁸ and that which we postulated for chelated heme reactions.²⁹ Both proximal-base hydrogen bonding and general-base catalysis are important in the heterolytic cleavage of the O—O bond (see reactions 13–16).

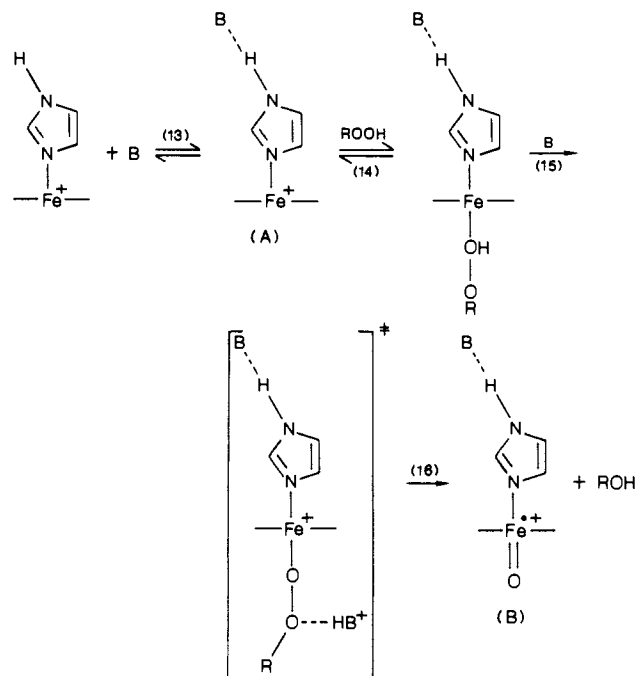

The existence of a hydrogen-bonded form such as (A) has been documented by the NMR studies of Walker²⁴ and La Mar,²¹ the oxidation–reduction studies of Sweigert et al.,²⁵ and other studies of Valentine et al.²⁶ Although the hydrogen-bonded form of the “oxene” (B) is only a postulate at present, it is reasonable to assume that the N—H bond would be made more acidic and this hydrogen bonding increased as the iron becomes more electron deficient. Further studies of this species are clearly warranted.

Finding that proximal hydrogen bonding increases the rate of heterolysis of the O—O bond suggests that deprotonation of the proximal base should have an even larger accelerating effect. This would help to explain the facile O—O bond heterolysis in cytochrome P-450 where, according to the crystal structure studies of Kraut and Poulos, there is no distal general base to assist this process. In that case the uncatalyzed ($\text{B}' = \text{H}_2\text{O}$) process of eq 12 would seem to be required.

Conclusions

We have found that proximal hydrogen bonding has little effect upon dioxygen or carbon monoxide binding, leaving the extraordinarily slow CO and O₂ dissociation rates in peroxidase as a mystery. On the other hand, hydrogen bonding of the proximal imidazole accelerates heterolytic O—O bond cleavage in the reactions of hydroperoxides or peracids with hemins, confirming the function of the proximal glutamate residue in CCP proposed by Kraut and Poulos.

Acknowledgment. We are grateful to the National Institutes of Health, Grant HL-13581, and the National Science Foundation, Grant CHE 84-20612 (T.G.T.), for support of this research and the Feinberg Graduate School of the Weizmann Institute of Science for a fellowship (R.P.-B.).

(32) Groves, J. T.; Watanabe, Y. *J. Am. Chem. Soc.* **1986**, *108*, 7834.

(33) (a) Zipples, M. F.; Lee, W. A.; Bruice, T. C. *J. Am. Chem. Soc.* **1986**, *108*, 4433. (b) Yuan, L.; Bruice, T. C. *Ibid.* **1985**, *107*, 512.

(34) Guilmet, E.; Meunier, B. *Tetrahedron Lett.* **1982**, *23*, 2449.